

R32





Wi-Fi

Duct type indoor unit

The duct-type indoor unit uses a DC motor, multi-stage airflow control, and flexible and convenient installation. All this meets the requirements for various construction objects, such as hotels, office buildings, shopping centers, apartments, cottages, etc.

REFINED BODY OF THE DEVICE

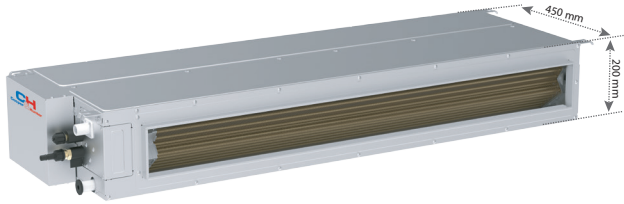
The duct unit is only 200mm thick and 450mm deep, which is suitable for spaces with different heights.



High static pressure duct units ranging from 7.1 kW to 8.5kW are only 900mm in length. They are suitable to be installed in corridors whose width is $\leq 1.2\text{m}$.

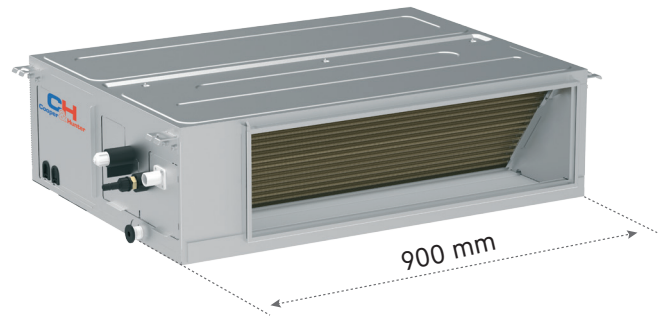

STANDARD EQUIPMENT DRAINAGE PUMP

The pressure of the pump for condensate removal can be up to 1000 mm, and the height of the vertical installation of the unit can be flexibly adjusted depending on the installation requirements.

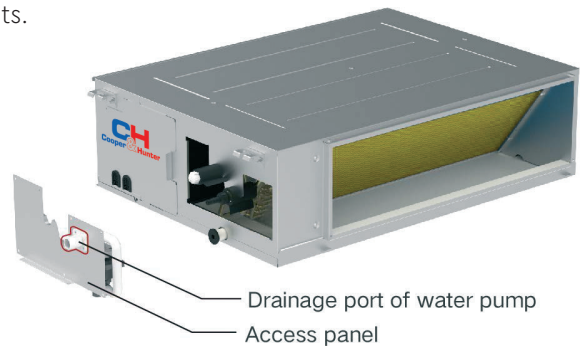
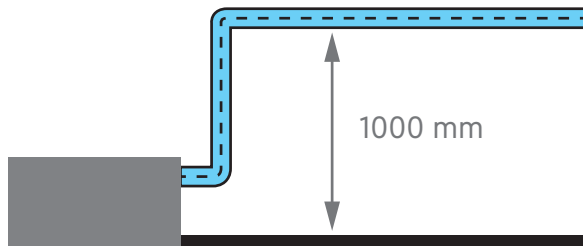

FRESH AIR SUPPLY FUNCTION

An air duct can be connected to the unit to supply fresh air to the room.



FLEXIBLE INSTALLATION

According to the location of the unit, you can choose one of two options for air intake, from below or from the side.

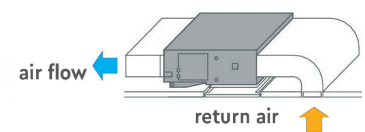
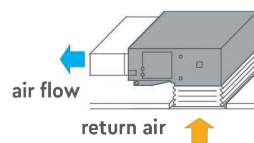

ADJUSTING THE PRESSURE OF THE FAN

The highest static pressure can be up to 30 Pa. From the control panel, you can change the static pressure of the fan according to the characteristics of the air duct network. 5 levels of external static pressure adjustment are available.

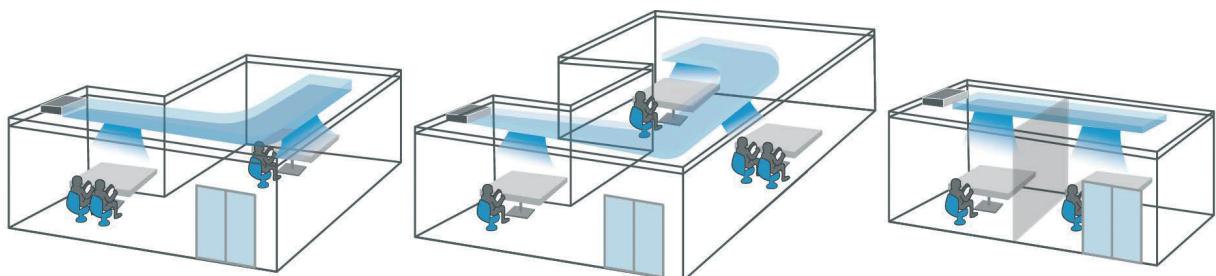

OVERALL DIMENSIONS OF THE INDOOR UNIT

CH-IDS035PRK2, CH-IDS050PRK2,
CH-IDH140PRK2, CH-IDH160PRK2.

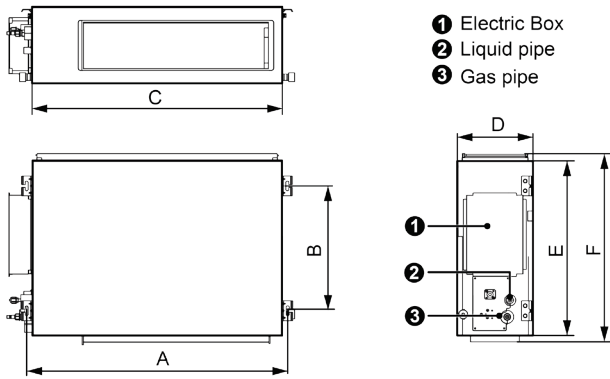

CH-IDS071PRK2, CH-IDS085PRK2,
CH-IDH100PRK2, CH-IDH125PRK2.

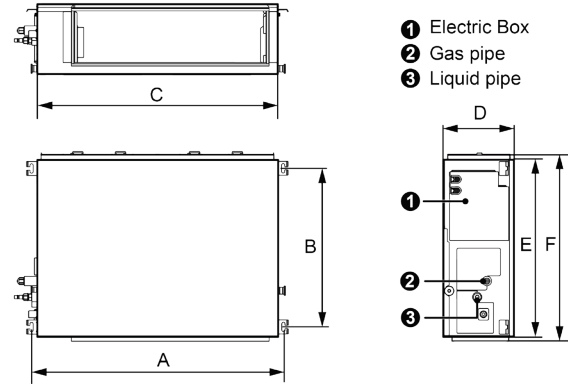

Units: mm

Dimensions/Model	A	B	C	D	E	F
CH-IDS035PRK2	760	415	700	200	450	486
CH-IDS050PRK2	1060	415	1000	200	450	486
CH-IDS071PRK2	942	590	900	260	655	692
CH-IDH085PRK2	942	590	900	260	655	692
CH-IDH100PRK2	1381	585	1340	260	655	697
CH-IDH125PRK2	1381	585	1340	260	655	697
CH-IDH140PRK2	1440	500	1400	300	700	754
CH-IDH160PRK2	1440	500	1400	300	700	754

OVERALL DIMENSIONS OF THE OUTDOOR UNIT

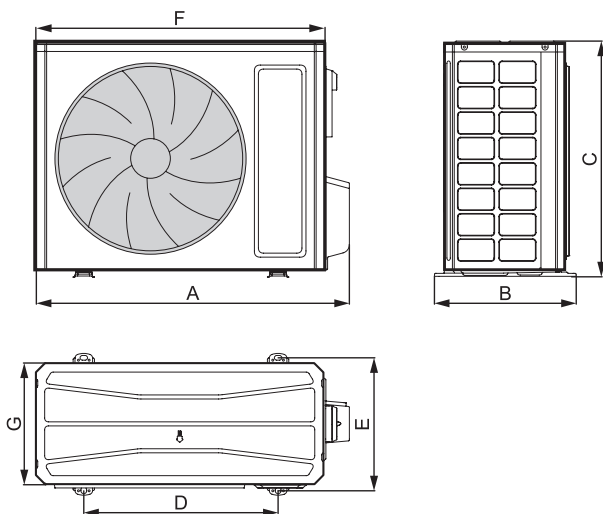

Units: mm

Dimensions/Model	A	B	C	D	E	F	G
CH-IU035RK2	732	330	553	455	310	675	285
CH-IU050RK2	802	350	555	512	331	745	300
CH-IU071RK2	958	402	660	570	371	889	340
CH-IU085RK2	958	402	660	570	371	889	340
CH-IU100RM2	1020	427	820	635	396	940	370
CH-IU125RM2	1020	427	820	635	396	940	370
CH-IU140RM2	1020	427	820	635	396	940	370
CH-IU160RM2	1070	427	960	755	396	990	370

TECHNICAL SPECIFICATIONS

Model	Indoor unit		CH-IDS035PRK2	CH-IDS050PRK2	CH-IDS071PRK2	CH-IDH085PRK2	CH-IDH100PRK2	CH-IDH125PRK2
	Outdoor unit		CH-IU035RK2	CH-IU050RK2	CH-IU071RK2	CH-IU085RK2	CH-IU100RK2	CH-IU125RK2
Capacity	Cooling	kW	3.5	5.3	7.1	8.5	10.5	12.1
		Btu/h	11900	18000	24200	29000	35800	41200
	Heating	kW	4.0	5.6	8.0	8.80	11.5	13.5
		Btu/h	13600	19100	27200	30000	39200	46000
EER/COP		3.40/4.00	3.50/3.95	3.70/4.00	3.40/3.90	3.50/4.10	3.38/3.65	
SEER/SCOP		6.50/4.00	6.30/4.00	6.60/4.10	6.40/4.10	6.40/4.20	6.10/4.10	
Energy efficiency grade		A++/A+	A++/A+	A++/A+	A++/A+	A++/A+	A++/A+	
Power supply		V/Hz/Ph	~220-240V/50Hz/1Ph					
Power input	Cooling	kW	1.03	1.51	1.92	2.50	3.00	3.58
	Heating	kW	1.00	1.42	2.00	2.25	2.80	3.70
Current input	Cooling	A	4.90	7.20	9.20	11.40	14.35	17.2
	Heating	A	4.80	6.80	9.60	10.30	13.4	17.7
Refrigerant charge volume		kg	0.57	0.85	1.50	1.50	2.10	2.25
Indoor unit								
Air flow volume (SH/H/M/L)	CFM		353/324/294/235	530/471/412/353	647/588/529/470	824/765/647/588	1000/941/824/710	1177/1059/941/824
	m ³ /h		600/550/500/400	900/800/700/600	1100/1000/900/800	1400/1300/1100/1000	1700/1600/1400/1200	2000/1800/1600/1400
ESP	Rated	Pa	25	25	25	37	37	50
	Range	Pa	0-80	0-80	0-160	0-160	0-160	0-160
Sound pressure		dB(A)	35/33/32/30	36/35/33/31	37/35/33/31	43/41/39/37	39/38/37/36	43/42/41/40
Dimension (WxDxH)	Outline	mm	700×450×200	1000×450×200	900×655×260	900×655×260	1340×655×260	1340×655×260
	Package	mm	1008×568×275	1308×568×275	1115×772×320	1115×772×320	1568×770×323	1568×770×323
Net weight/Gross weight		kg	18.0/22.0	24.0/29.0	29.5/33.5	29.5/33.5	43.0/49.0	43.0/49.0
Outdoor unit								
Sound pressure		dB(A)	48	52	55	57	57	58
Dimension (WxDxH)	Outline	mm	675×285×553	745×300×555	889×340×660	889×340×660	940×370×820	940×370×820
	Package	mm	794×376×605	872×398×609	1032×456×730	1032×456×730	1093×497×885	1093×497×885
Net weight/Gross weight		kg	24.5/27.0	30.5/33.0	41.5/45.0	46.0/50.0	65.0/72.0	66.0/73.0
Connecting pipe	Liquid pipe	inch	1/4 (6.35)	1/4 (6.35)	3/8 (9.52)	3/8 (9.52)	3/8 (9.52)	3/8 (9.52)
	Gas pipe	(mm)	3/8 (9.52)	1/2 (12.7)	5/8 (15.9)	5/8 (15.9)	5/8 (15.9)	5/8 (15.9)
	Max. distance (Height/Length)	m	15/30	20/30	20/30	25/30	30/75	30/75

Model	Indoor unit		CH-IDH140PRK2	CH-IDH100PRK2	CH-IDH125PRK2	CH-IDH140PRK2	CH-IDH160RK2	
	Outdoor unit		CH-IU140RK2	CH-IU100RM2	CH-IU125RM2	CH-IU140RM2	CH-IU160RM2	
Capacity	Cooling	kW	13.4	10.5	12.1	13.4	16.0	
		Btu/h	45700	35800	41200	45700	54500	
	Heating	kW	15.50	11.5	13.5	15.50	17.0	
		Btu/h	52900	39200	46000	52900	58000	
EER/COP		2.98/3.44	3.50/4.10	3.38/3.65	2.98/3.44	2.96/3.62		
SEER/SCOP		6.10/4.00	6.40/4.20	6.10/4.10	6.10/4.00	6.10/4.00		
Energy efficiency grade		A++/A+	A++/A+	A++/A+	A++/A+	A++/A+		
Power supply		V/Hz/Ph	~220-240V/50Hz/1Ph		~380-415V/50Hz/3Ph			
Power input	Cooling	kW	4.50	3.00	3.58	4.50	5.40	
	Heating	kW	4.50	2.80	3.70	4.50	4.70	
Current input	Cooling	A	20.60	4.8	5.7	6.80	9.20	
	Heating	A	20.60	4.45	5.9	6.80	8.00	
Refrigerant charge volume		kg	2.80	2.10	2.25	2.80	3.50	
Indoor unit								
Air flow volume (SH/H/M/L)	CFM		1354/1236/1059/883	1000/941/824/710	1177/1059/941/824	1354/1236/1059/883	1529/1354/1176/1000	
	m ³ /h		2300/2100/1800/1500	1700/1600/1400/1200	2000/1800/1600/1400	2300/2100/1800/1500	2600/2300/2000/1700	
ESP	Rated	Pa	50	37	50	50	50	
	Range	Pa	0-200	0-160	0-160	0-200	0-200	
Sound pressure		dB(A)	43/42/40/38	39/38/37/36	43/42/41/40	43/42/40/38	46/44/42/40	
Dimension (WxDxH)	Outline	mm	1400×700×300	1340×655×260	1340×655×260	1400×700×300	1400×700×300	
	Package	mm	1601×813×365	1568×770×323	1568×770×323	1601×813×365	1601×813×365	
Net weight/Gross weight		kg	52.0/58.0	43.0/49.0	43.0/49.0	52.0/58.0	55.0/62.0	
Outdoor unit								
Sound pressure		dB(A)	59	57	58	59	60	
Dimension (WxDxH)	Outline	mm	940×370×820	940×370×820	940×370×820	940×370×820	990×370×960	
	Package	mm	1093×497×885	1093×497×885	1093×497×885	1093×497×885	1153×478×1110	
Net weight/Gross weight		kg	73.0/80.0	75.0/82.0	76.0/83.0	81.0/88.0	94.0/103.0	
Connecting pipe	Liquid pipe	inch (mm)	3/8 (9.52)	3/8 (9.52)	3/8 (9.52)	3/8 (9.52)	3/8 (9.52)	
	Gas pipe		5/8 (15.9)	5/8 (15.9)	5/8 (15.9)	5/8 (15.9)	5/8 (15.9)	
	Max. distance (Height/Length)	m	30/75	30/75	30/75	30/75	30/75	

Performance and consumption data are determined at the following air parameters
 Cooling: indoor temperature DB/WB: 27/19°C, outdoor temperature DB/WB: 35/24°C
 Heating: indoor temperature DB/WB: 20/15°C, outdoor temperature DB/WB: 7/6°C